

Catifa 53

Design by Lievore Altherr Molina, 2012

Art. 2084

Chair with four leg solid oak base (natural oak, bleached oak, wengè, teak colour) and matt polypropylene single-colour or, alternatively, the shell can be upholstered in hard leather grade 1 (CT) or hard leather grade 2 (CU). Provided with glides suitable for different surfaces.



Dimensions *

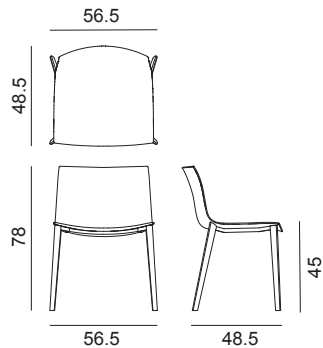

* File CAD 2D - 3D available for download at www.arper.com

Frame Base



Shell

Polypropylene



PO
Polypropylene
one color

Hard leather Grade 1 and Grade 2



CT CU

arper

F +39 0422 791800

T +39 0422 7918

www.arper.com

Catifa 53

Design by Lievore Altherr Molina, 2012

Accessories:



Cushion Art. 0231



Link Art. 0258



Basket Art. 2014

SHIPMENT DETAILS

Art.2084

1 pz = 2 - kg 9,5/ m³ 0,3

4 pz = 2 - kg 26,54/ m³ 0,37

RESISTANCE TEST

- EN 1728:2000 - EN 15373:2007 6.12
- EN 1728:2000 - EN 15373:2007 6.15
- EN 1728:2000 - EN 15373:2007 6.2.1
- EN 1728:2000 - EN 15373:2007 6.7
- EN 1022:05
- EN 1728:2000 - EN 15373:2007 6.13
- EN 1728:2000 - EN 15373:2007 6.16
- EN 1728:2000 - EN 15373:2007 6.2.2
- EN 1728:2000 - EN 15373:2007 6.8

FIRE RETARDANT TEST

BS5852/90 Sez.5 cigarette match polypropylene • BS5852 Sch. 5 Part 1 CT CU

ENVIRONMENTAL CERTIFICATIONS



arper

F +39 0422 791800

T +39 0422 7918

www.arper.com

Catifa 53

Design by Lievore Altherr Molina, 2012

Art. 2085

Chair with four leg solid oak base (natural oak, bleached oak, wengé, teak colour) and shell upholstered in leather, faux leather, fabric or customer's material. Provided with glides suitable for different surfaces.



Dimensions *

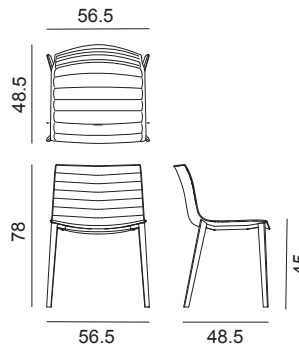

* File CAD 2D - 3D available for download at www.arper.com

Frame Base

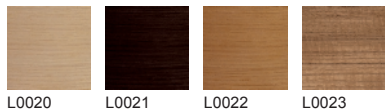

Shell

Carded In

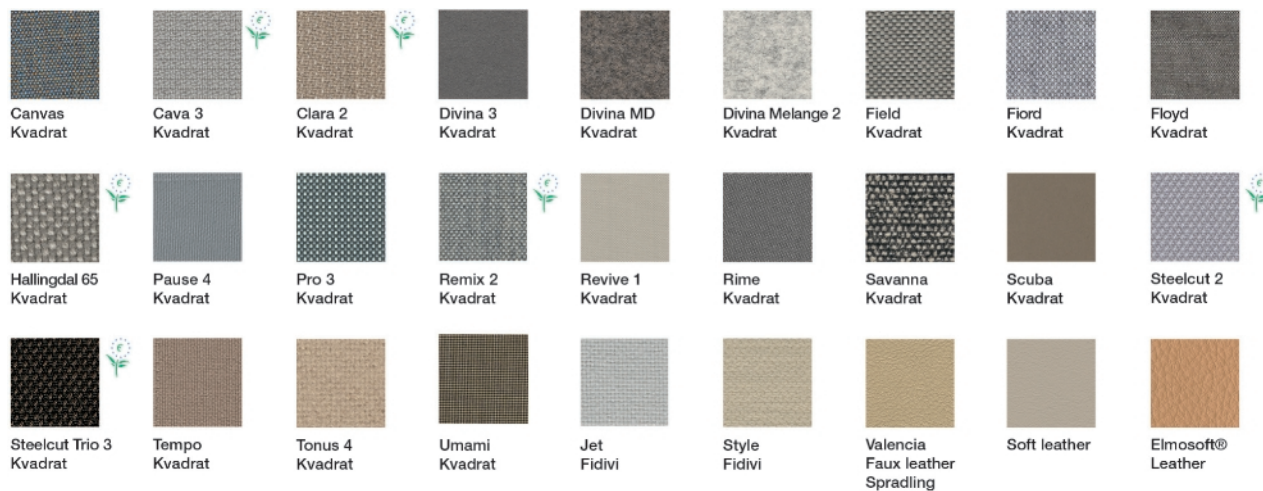

Graded In

kvadrat

camira



DESIGN
TEX



Gabriel



svensson

maharam

SergeFerrari

Catifa 53

Design by Lievore Altherr Molina, 2012

Accessories:



Link Art. 0258



Basket Art. 2014

SHIPMENT DETAILS

Art.2085

1 pz = 2  - kg 10,5/ m² 0,3

4 pz = 2  - kg 30,94/ m² 0,41

TECHNICAL SPECIFICATIONS

Art.2085

COL requirement m² 1.78

H 140 cm. COM Meterage ml 1.21

RESISTANCE TEST

- EN 1728:2000 - EN 15373:2007 6.12
- EN 1728:2000 - EN 15373:2007 6.15
- EN 1728:2000 - EN 15373:2007 6.2.1
- EN 1728:2000 - EN 15373:2007 6.7
- EN 1022:05
- EN 1728:2000 - EN 15373:2007 6.13
- EN 1728:2000 - EN 15373:2007 6.16
- EN 1728:2000 - EN 15373:2007 6.2.2
- EN 1728:2000 - EN 15373:2007 6.8

FIRE RETARDANT TEST

BS5852 i.s. 5 Cava 3 Soft leather Elmosoft Hallingdal 65 Pro 3 Tonus 4 • Classe 1IM Cava 3 Divina MD Divina Melange 2 Divina 3 Hallingdal 65 Pro 3 Soft leather Tonus 4 Faux leather Valencia • California TB117-2013 Cava 3 Clara Canvas Divina MD Divina Melange 2 Divina 3 Soft leather Elmosoft Field Hallingdal 65 Jet Jumper 3 Pro 3 Soft leather Pause 4 Remix 2 Savanna Steelcut 2 Scuba Steelcut Trio 2 Steelcut Trio 3 Sunniva Sunniva 2 Tonus 4 Tempo Faux leather Valencia • BS5852 Sch. 4 Part 1 Cava 3 Divina MD Divina Melange 2 Divina 3 Soft leather Elmosoft Hallingdal 65 Pro 3 Tonus 4 Faux leather Valencia • BS5852 Sch. 5 Part 1 Cava 3 Clara Canvas Divina MD Divina Melange 2 Divina 3 Soft leather Elmosoft Hallingdal 65 Soft leather Remix 2 Savanna Steelcut 2 Steelcut Trio 2 Steelcut Trio 3 Tonus 4 Faux leather Valencia • EN 1021 - 1 Divina MD Divina Melange 2 Divina 3 Soft leather Elmosoft Field Hallingdal 65 Pro 3 Soft leather • EN 1021 - 2 Divina MD Divina Melange 2 Divina 3 Soft leather Elmosoft Field Hallingdal 65 Pro 3 Soft leather

ENVIRONMENTAL CERTIFICATIONS



arper

F +39 0422 791800

T +39 0422 7918

www.arper.com

Catifa 53

Design by Lievore Altherr Molina, 2012

Art. 2086

Chair with four leg solid oak base (natural oak, bleached oak, wengé, teak colour) and matt polypropylene shell with front upholstery in fabric, leather, faux leather or customer's material. Provided with glides suitable for different surfaces.



Dimensions *

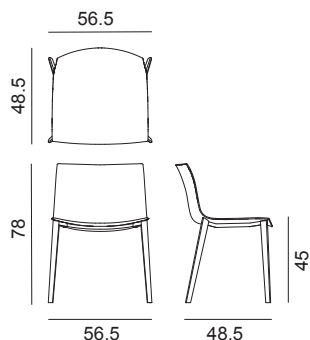

* File CAD 2D - 3D available for download at www.arper.com

Frame Base

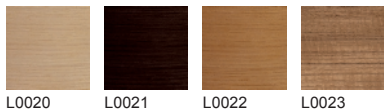

Shell

Polypropylene



PO
Polypropylene
one color

Carded In



Graded In

kvadrat

camira



DESIGN
TEX



Gabriel



svensson

maharam

Serge Ferrari

Catifa 53

Design by Lievore Altherr Molina, 2012

Accessories:



Link Art. 0258



Basket Art. 2014

SHIPMENT DETAILS

Art.2086

1 pz = 2  - kg 11,3/ m² 0,3

4 pz = 2  - kg 34,2/ m² 0,41

TECHNICAL SPECIFICATIONS

Art.2086

COL requirement m² 0.84

H 140 cm. COM Meterage ml 0.72

RESISTANCE TEST

- EN 1728:2000 - EN 15373:2007 6.12
- EN 1728:2000 - EN 15373:2007 6.15
- EN 1728:2000 - EN 15373:2007 6.2.1
- EN 1728:2000 - EN 15373:2007 6.7
- EN 1022:05

- EN 1728:2000 - EN 15373:2007 6.13
- EN 1728:2000 - EN 15373:2007 6.16
- EN 1728:2000 - EN 15373:2007 6.2.2
- EN 1728:2000 - EN 15373:2007 6.8

FIRE RETARDANT TEST

BS5852 i.s. 5 Cava 3 Soft leather Elmosoft Hallingdal 65 Pro 3 Tonus 4 • Classe 1IM Cava 3 Divina MD Divina Melange 2 Divina 3 Hallingdal 65 Pro 3 Soft leather Tonus 4 Faux leather Valencia • California TB117-2013 Cava 3 Clara Canvas Divina MD Divina Melange 2 Divina 3 Soft leather Elmosoft Field Hallingdal 65 Jet Jumper 3 Pro 3 Soft leather Pause 4 Remix 2 Savanna Steelcut 2 Scuba Steelcut Trio 2 Steelcut Trio 3 Sunniva Sunniva 2 Tonus 4 Tempo Faux leather Valencia • BS5852 Sch. 4 Part 1 Cava 3 Divina MD Divina Melange 2 Divina 3 Soft leather Elmosoft Hallingdal 65 Pro 3 Tonus 4 Faux leather Valencia • BS5852 Sch. 5 Part 1 Cava 3 Clara Canvas Divina MD Divina Melange 2 Divina 3 Soft leather Elmosoft Hallingdal 65 Soft leather Remix 2 Savanna Steelcut 2 Steelcut Trio 2 Steelcut Trio 3 Tonus 4 Faux leather Valencia • EN 1021 - 1 Divina MD Divina Melange 2 Divina 3 Soft leather Elmosoft Field Hallingdal 65 Pro 3 Soft leather • EN 1021 - 2 Divina MD Divina Melange 2 Divina 3 Soft leather Elmosoft Field Hallingdal 65 Pro 3 Soft leather

ENVIRONMENTAL CERTIFICATIONS



arper

F +39 0422 791800

T +39 0422 7918

www.arper.com

Catifa 53

Design by Lievore Altherr Molina, 2012

Art. 2087

Chair with four leg solid oak base and double-curved wood shell available in four finishes (natural oak, bleached oak, wengé, teak). Shell and base can be ordered with the same finish or different finishes can be combined together. Provided with glides suitable for different surfaces.



Dimensions *

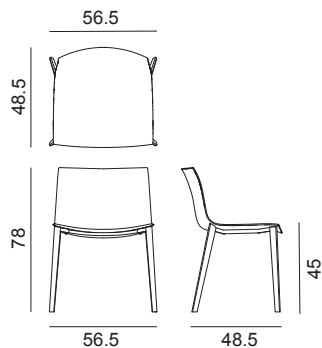

* File CAD 2D - 3D available for download at www.arper.com

Frame Base



Shell

Wood



arper

F +39 0422 791800

T +39 0422 7918

www.arper.com

Catifa 53

Design by Lievore Altherr Molina, 2012

Accessories:



Cushion Art. 0231



Link Art. 0258



Basket Art. 2014

SHIPMENT DETAILS

Art.2087

1 pz = 2  - kg 9,42/ m³ 0,3

4 pz = 2  - kg 25,94/ m³ 0,37

RESISTANCE TEST

- EN 1728:2012 - EN 16139:2013 6.15
- EN 1728:2012 - EN 16139:2013 6.17
- EN 1728:2012 - EN 16139:2013 6.24
- EN 1728:2012 - EN 16139:2013 6. 4

- EN 1728:2012 - EN 16139:2013 6.16
- EN 1728:2012 - EN 16139:2013 6.18
- EN 1728:2012 - EN 16139:2013 6.25
- EN 1728:2012 - EN 16139:2013 6. 5

TECHNICAL SPECIFICATIONS

FIRE RETARDANT TEST

BS5852/90 Sez.5 cigarette match LG • Classe 1 LG

ENVIRONMENTAL CERTIFICATIONS



arper

F +39 0422 791800

T +39 0422 7918

www.arper.com

Catifa 53

Design by Lievore Altherr Molina, 2012

Art. 2088

Chair with four leg solid oak base and double-curved wood shell available in four finishes (natural oak, bleached oak, wengé, teak) with front upholstery in fabric, leather, faux leather or customer's material. Provided with glides suitable for different surfaces.



Dimensions *

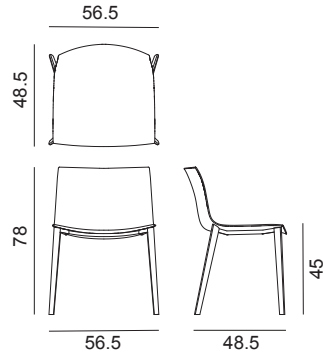

* File CAD 2D - 3D available for download at www.arper.com

Frame Base

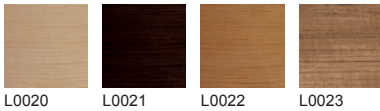

Shell

Wood

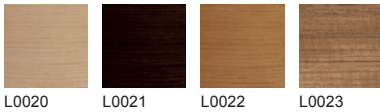

Carded In

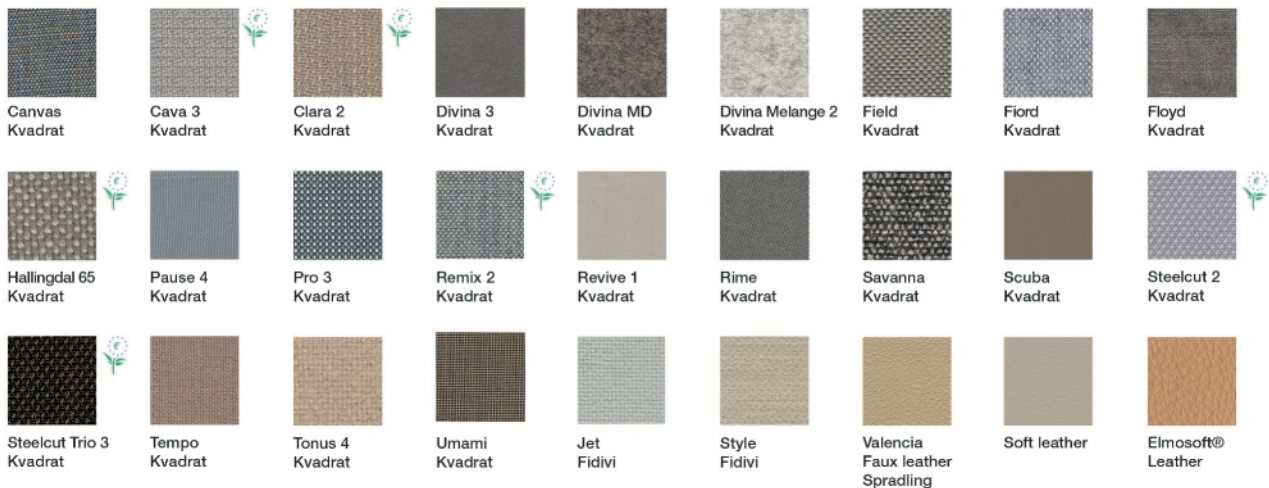

Graded In

kvadrat

camira



DESIGN
TEX



Gabriel



svensson

maharam

Serge Ferrari

Catifa 53

Design by Lievore Altherr Molina, 2012

Accessories:



Link Art. 0258



Basket Art. 2014

SHIPMENT DETAILS

Art.2088

1 pz = 2  - kg 11,3/ m² 0,3

4 pz = 2  - kg 34,2/ m² 0,41

TECHNICAL SPECIFICATIONS

Art.2088

COL requirement m² 0.84

H 140 cm. COM Meterage ml 0.72

RESISTANCE TEST

- EN 1728:2012 - EN 16139:2013 6.15
- EN 1728:2012 - EN 16139:2013 6.17
- EN 1728:2012 - EN 16139:2013 6.24
- EN 1728:2012 - EN 16139:2013 6. 4
- EN 1728:2012 - EN 16139:2013 6.16
- EN 1728:2012 - EN 16139:2013 6.18
- EN 1728:2012 - EN 16139:2013 6.25
- EN 1728:2012 - EN 16139:2013 6. 5

FIRE RETARDANT TEST

BS5852 i.s. 5 Cava 3 Soft leather Elmosoft Hallingdal 65 Pro 3 Tonus 4 • Classe 1IM Cava 3 Divina MD Divina Melange 2 Divina 3 Hallingdal 65 Pro 3 Soft leather Tonus 4 Faux leather Valencia • California TB117-2013 Cava 3 Clara Canvas Divina MD Divina Melange 2 Divina 3 Soft leather Elmosoft Field Hallingdal 65 Jet Jumper 3 Pro 3 Soft leather Pause 4 Remix 2 Savanna Steelcut 2 Scuba Steelcut Trio 2 Steelcut Trio 3 Sunniva Sunniva 2 Tonus 4 Tempo Faux leather Valencia • BS5852 Sch. 4 Part 1 Cava 3 Divina MD Divina Melange 2 Divina 3 Soft leather Elmosoft Hallingdal 65 Pro 3 Tonus 4 Faux leather Valencia • BS5852 Sch. 5 Part 1 Cava 3 Clara Canvas Divina MD Divina Melange 2 Divina 3 Soft leather Elmosoft Hallingdal 65 Soft leather Remix 2 Savanna Steelcut 2 Steelcut Trio 2 Steelcut Trio 3 Tonus 4 Faux leather Valencia • EN 1021 - 1 Divina MD Divina Melange 2 Divina 3 Soft leather Elmosoft Field Hallingdal 65 Pro 3 Soft leather • EN 1021 - 2 Divina MD Divina Melange 2 Divina 3 Soft leather Elmosoft Field Hallingdal 65 Pro 3 Soft leather

ENVIRONMENTAL CERTIFICATIONS



arper

F +39 0422 791800

T +39 0422 7918

www.arper.com

Catifa 53

Design by Lievore Altherr Molina, 2013

Art. 3118

Chair with four leg solid oak base (natural oak, bleached oak, wengé, teak colour) and white polypropylene shell upholstered with a removable non-washable cover in leather, faux leather, fabric or customer's own material. The chair is provided already fitted with the cover. Provided with glides suitable for different surfaces.



Dimensions *

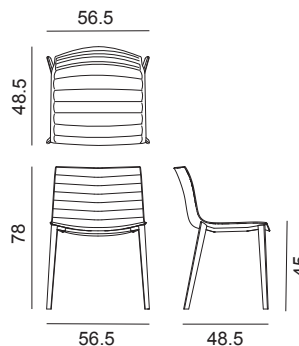

* File CAD 2D - 3D available for download at www.arper.com

Frame Base



Shell

Carded In

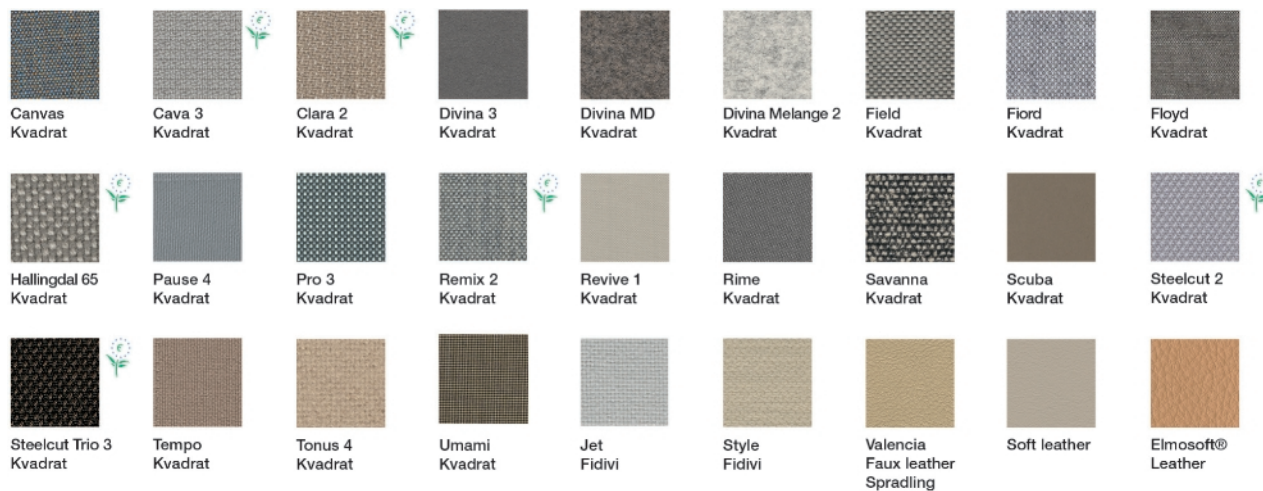

Graded In

kvadrat

camira



DESIGN
TEX



Gabriel



svensson

maharam

Serge Ferrari

arper

F +39 0422 791800

T +39 0422 7918

www.arper.com

Catifa 53

Design by Lievore Altherr Molina, 2013

Accessories:



Link Art. 0258



Basket Art. 2014

SHIPMENT DETAILS

Art.3118

1 pz = 2  - kg 10,5/ m² 0,3

4 pz = 2  - kg 30,94/ m² 0,41

TECHNICAL SPECIFICATIONS

Art.3118

COL requirement m² 2,09

H 140 cm. COM Meterage ml 1,23

The cover stitching comes in the same color as the upholstery. Stitching on cover 1 and 3 comes in white or black, to customer's choice.

RESISTANCE TEST

- EN 1728:2000 - EN 15373:2007 6.12
- EN 1728:2000 - EN 15373:2007 6.15
- EN 1728:2000 - EN 15373:2007 6.2.1
- EN 1728:2000 - EN 15373:2007 6.7
- EN 1022:05
- EN 1728:2000 - EN 15373:2007 6.13
- EN 1728:2000 - EN 15373:2007 6.16
- EN 1728:2000 - EN 15373:2007 6.2.2
- EN 1728:2000 - EN 15373:2007 6.8

FIRE RETARDANT TEST

BS5852 i.s. 5 Cava 3 Soft leather Elmosoft Hallingdal 65 Pro 3 Tonus 4 • Classe 1IM Cava 3 Divina MD Divina Melange 2 Divina 3 Hallingdal 65 Pro 3 Soft leather Tonus 4 Faux leather Valencia • California TB117-2013 Cava 3 Clara Canvas Divina MD Divina Melange 2 Divina 3 Soft leather Elmosoft Field Hallingdal 65 Jet Jumper 3 Pro 3 Soft leather Pause 4 Remix 2 Savanna Steelcut 2 Scuba Steelcut Trio 2 Steelcut Trio 3 Sunniva Sunniva 2 Tonus 4 Tempo Faux leather Valencia • BS5852 Sch. 4 Part 1 Cava 3 Divina MD Divina Melange 2 Divina 3 Soft leather Elmosoft Hallingdal 65 Pro 3 Tonus 4 Faux leather Valencia • BS5852 Sch. 5 Part 1 Cava 3 Clara Canvas Divina MD Divina Melange 2 Divina 3 Soft leather Elmosoft Hallingdal 65 Soft leather Remix 2 Savanna Steelcut 2 Steelcut Trio 2 Steelcut Trio 3 Tonus 4 Faux leather Valencia • EN 1021 - 1 Divina MD Divina Melange 2 Divina 3 Soft leather Elmosoft Field Hallingdal 65 Pro 3 Soft leather • EN 1021 - 2 Divina MD Divina Melange 2 Divina 3 Soft leather Elmosoft Field Hallingdal 65 Pro 3 Soft leather

ENVIRONMENTAL CERTIFICATIONS



arper

F +39 0422 791800

T +39 0422 7918

www.arper.com